

**SDJCR**

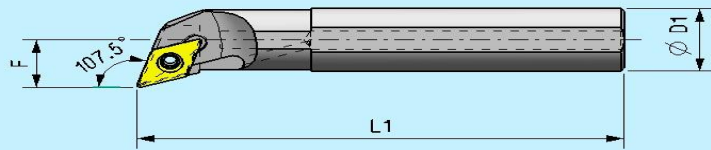

**SDNCN**



**SDQCR**

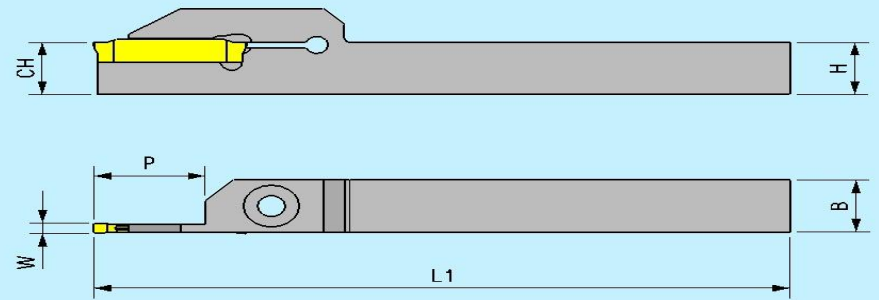

**GPTR**

APPLICATION

**SDJCR**

**SDNCN**

**SDQCR**

**GPTR**

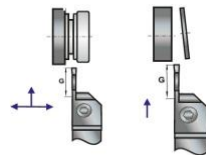
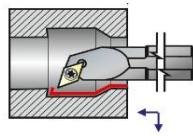
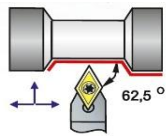
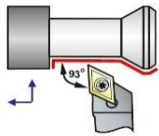

APPLICATION

- **SDJCR** 60° Profile Turning and Facing Tool RH side
- **SDNCN** V' Turning/Threading 55°
- **SDQCR** Internal Profiling with cutting edge angle 107°30'.
- **GPTR** Right Hand side Tool Holder with double ended Insert for External Parting,Grooving and Turning .

ISO DESIGNATION	Ø D1	H	B	CH	W	F	P	L1	D min.	INSERT	Ordering No.	SPARE PARTS		
SDJCR 1010 H07		10	10	10		12		100		DCMT 0702 04	773651	DCMT 0702 04 INSERT	M 2.5 TORX SCREW	T-8 TORX KEY
SDNCN 1010 H07		10	10	10		5		100		DCMT 0702 04	773713			
A08H SDQCR 07	8					6		100	10	DCMT 0702 04	710901			
GPTR 1010 K2N		10	10	10	2		15	125		DGN 2N	775210	DGN 2N INSERT	M 4 ALLEN BOLT	3mm ALLEN KEY

