

8" MINI SHEAR/BRAKE

ASSEMBLY AND OPERATING INSTRUCTIONS

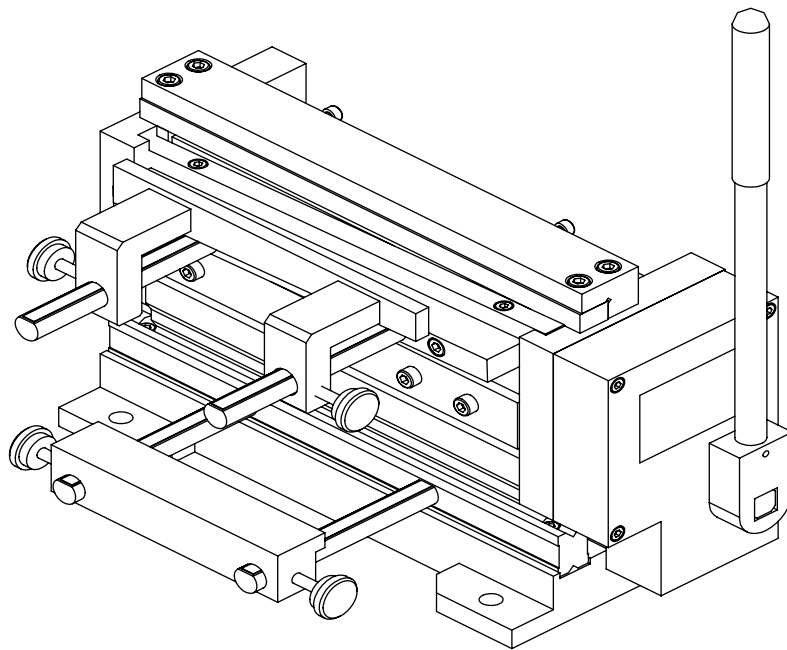

SPECIFICATIONS

Base dimension		9" × 5"
Blade Length		8"
Maximum Cutting and Bending Length		7-7/8"
Capacity	Aluminum	.040" (1.0mm)
	Copper	.040" (1.0mm)
	Circuit Board	1/16" (1.5mm)
	Tinplate Sheet Metal	.040" (1.0mm)
	brass	.040" (1.0mm)

SAVE THIS MANUAL

You will need the manual for the safety warning and cautions, assembly instructions, operating procedures and maintenance procedures, trouble shooting , parts list and diagram. **Keep you invoice with this manual. Write the invoice number on the inside of the front cover.** Keep the manual and invoice in a safe, dry place for future reference.

SAFETY WARNING & CAUTIONS

WARNING: When using electric tools, machines, or equipment, basic safety precautions should always be followed to reduce the risk of fire, electric shock, and personal injury.
READ ALL INSTRUCTION BEFORE USING THIS TOOL!

- 1. KEEP WORK AREA CLEAN.** Cluttered areas invite injuries.
- 2. OBSERVE WORK AREA CONDITIONS.** Do not use machines or powered tools in damp, wet, or poorly lit locations. Don't expose to rain. Keep work area well lit. Do not use electrically powered tools in the presence of flammable gases or liquids.
- 3. KEEP CHILDREN AWAY.** Children must never be allowed in the work area. Do not let them handle machines, tools, or extension cords.
- 4. STORE IDLE EQUIPMENT.** When not in use, tools must be locked up in a dry location to inhibit rust. Always lock up tools and keep out of reach of children.
- 5. DO NOT FORCE THE TOOLS.** It will do the job better and more safety at the rate for which it was intended. Do not use inappropriate attachments in an attempt to exceed the tool's capacities.
- 6. USE THE RIGHT TOOL FOR THE JOB.** Do not attempt to force a small tool or attachment to do the work of a large industrial tool. Do not use a tool for purpose for which it was not intended.

- 7. DRESS PROERLY.** Do not wear loose clothing or jewelry as they can be caught in moving parts. Protective, electrically non-conductive clothes and non-skid footwear are recommended when working. Wear restrictive hair covering to contain long hair.
- 8. USE EYE AND EAR PROTECTION.** Always wear ANSI approved chemical splash goggles when working with chemicals. Always wear ANSI approved impact safety goggles at other times. Wear a full-face shield if you are producing metal filings or wood chips. Wear an ANSI approved dust mask or respirator when working around metal, and chemical dusts and mists.
- 9. DO NOT ABUSE THE POWER CORD.** Do not yank it to disconnect it from the receptacle. Do not carry tools by the cord.
- 10. DO NOT OVERREACH.** Keep proper footing and balance at all times. Do not reach over or across running machines.
- 11. MAINTAIN TOOLS WITH CARE.** Keep tools sharp and clean for better and safer performance. Follow instructions for lubricating and changing accessories. The handles must be kept clean, dry, and free from oil and grease at all times.
- 12. DISCONNECT POWER.** Unplug when not in use, before servicing, and when changing accessories.
- 13. REMOVE ADJUSTING KEYS AND WRENCHES.** Make it a habit to check that keys and adjusting wrenches are removed from the tools or machine work surface before plugging it in.
- 14. AVOID UNINTENTIONAL STARTING.** Be sure the switch is in the OFF position when not in use and before plugging in. Do not carry any tool with your finger on the trigger, whether it is plugged in or not.
- 15. OUTDOORS EXTENSIONS CORDS.** When the equipment is operated outdoors, use only extension cords intended for outside use. See chart under "Extension Cords" for the proper AWG rating depending on the length of the cord(s) being used.
- 16. STAY ALERT.** Watch what you are doing; use common sense. Do not operate any tool when you are tired.

17. CHECK DAMAGED PARTS. Before using any tool, any part that appears damaged should be carefully checked to determine that it would operate properly and perform its intended function. Check for alignment and binding of moving parts; any broken parts or mounting fixtures; and any other condition that may affect proper operation. Any part that is damaged should be properly repaired or replaced by a qualified technician. Do not use the tool if any switch does not turn on and off properly.

18. GUARD AGAINST ELECTRIC SHOCK. Prevent body contact with grounded surfaces such as pipes, radiators, ranges, and refrigerator enclosures.

19. REPLACEMENT PARTS AND ACCESSORIES. When servicing, use only identical replacement parts. Use of any other parts will void the warranty. Only use accessories intended for use with this tool. Approved accessories are available from the distributor.

20. DO NOT OPERATE TOOL IF UNDER THE INFLUENCE OF ALCOHOL OR DRUGS. Read warning labels on prescriptions to determine if your judgment of reflexes are impaired while taking drugs. If there is any doubt, do not operate the tool.

Note: The warning and instructions contained in this instruction manual cannot cover all possible conditions and situation that may occur when using this product. It must be understood that common sense and caution are factors, which cannot be built into this product. These factors must be supplied by the person whom operating this piece of equipment.

UNPACKING

No.	Item Description	Quantity
1	Shear/Brake Assembly	1
2	Allen Wrench Set	2
3	Bending Tool	1
4	Bending Tool	1
5	Bending Tool	1
6	Bending Tool	1
7	Handle Assembly	1

ASSEMBLY

Your Shear/Brake comes assembled with the BENDING TOOL (#27) already installed. To complete assemble and prepare your Shear/Brake for use, follow the Steps below.

Mounting to a Wood Workbench

Step 1: Measure the thickness of your workbench. It is suggested that to securely mount your Shear/Brake to a wooden workbench, you mount lengths of wood underneath the mounting points.

Step 2: Maybe you need purchase four bolts, nuts, and flat washers (these item not supply with the SHEAR/BRAKE) the appropriate length for your workbench plus 1" of length for the Shear/Brake.

Step 3: Mark and drill holes through the workbench, using the Base (#1) as a template, for the four Mounting Holes on the BASE of the Shear/Brake.

Step 4: Position the Shear/Brake on your workbench and line up the holes you drilled in Step 3 with the Mounting Holes in the BASE.

Step 5: Insert the BOLT & NUT SET (Supply these by yourself) into the Mounting Holes and through the workbench as shown in Figure 1.

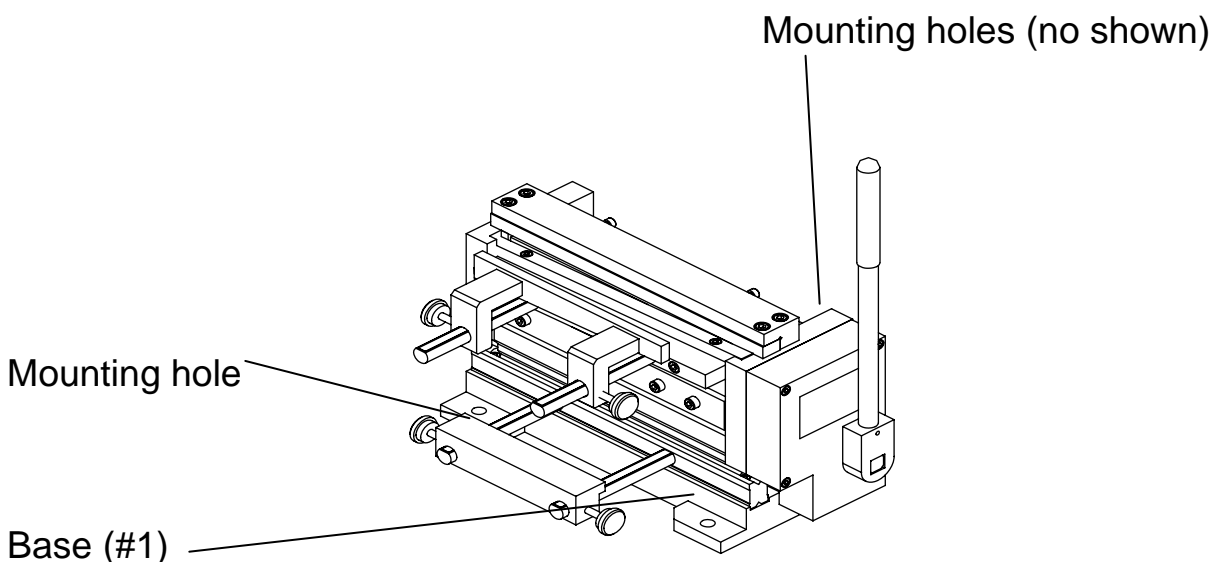

Figure 1 – Mounting Shear/brake to a Wood workbench

Step 6: Tighten Bolts.

Mounting to a Metal Workbench

Step 1: Measure the thickness of your workbench. It is suggested that a metal reinforcing plate be cut and ready to mount beneath the workbench for step 7.

Step 2: Maybe you need purchase four bolts, nuts, and flat washers (these item not supply with the SHEAR/BRAKE) the appropriate length for your workbench plus 1" of length for the Shear/Brake.

Step 3: Mark and drill holes through the workbench, using the BASE as a template, for the four Mounting Holes on the Base of the Shear/Brake.

Step 4: Mark and drill the reinforcing plate, using the BASE of the Shear/Brake as a template, for the four Mounting Holes on the BASE of the Shear/Brake.

Step 5: Position the Shear/Brake on your workbench and line up the holes you drilled in Step 3 with the holes in the BASE.

Step 6: Mount the Shear/Brake to the workbench. Refer to Figure 1.

Step 7: Remember to attach the reinforcing plate underneath the workbench then thread on the nuts and tighten the bolts.

Handle Assembly

Step 1: Loosen the Knob located at the Handle Pivot on the right side of the Shear/Brake.

Step 2: Insert the HAND LEVER (#6) into the Handle Pivot, grooved end first. When the groove in the HAND LEVER is centered in the Handle Pivot, tighten the Knob as shown in Figure 2.

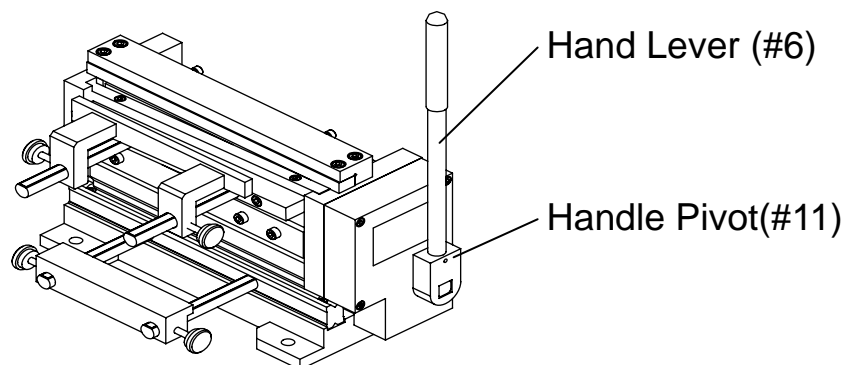

Figure 2 – Hand lever Installation

Bending Tool Adjustment and Removal

The BENDING TOOL (#27, #37) come in various widths and can be used for varying sizes of box and pan forming. When forming a smaller box or pan, choose the desired size BENDING TOOL finger, center it and remove the others. See the Steps below for adjustment instructions.

Step 1: Loose the HEX HEAD SCREWS (#25) holding the BENDING TOOL Fingers in place.

Step 2: Remove any unneeded BENDING TOOL fingers by sliding them out the left of the Shear/Brake as shown in figure 3.

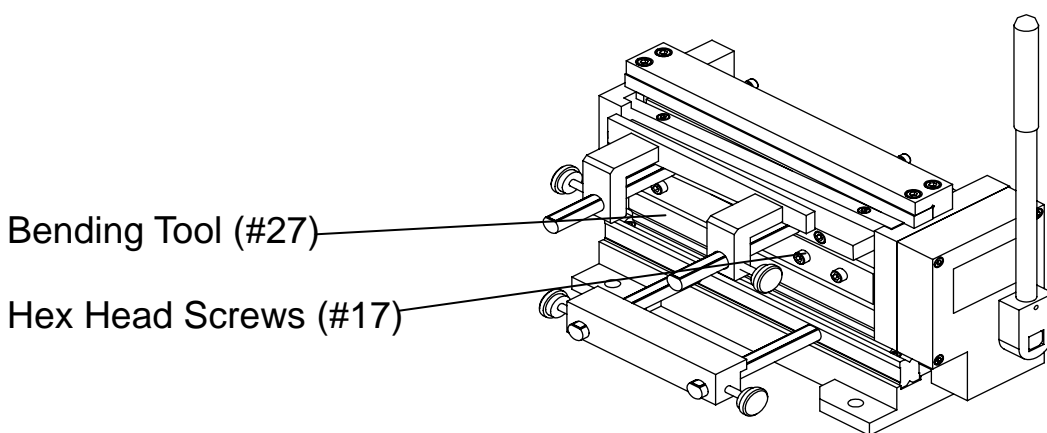

Figure 3 – Bending Tool Removal

Step 3: Insert any needed BENDING TOOLS appropriate for the job you will be doing behind the CLAMPING BAR (#26).

Step 4: lower the HAND LEVER (#6) to lower the installed BENDING TOOLS. This will adjust the alignment of the BENDING TOOLS.

Step 5: Tighten the HEX HEAD SCREWS.

Bending Prism Adjustment

You can adjust the radius of the bend you will make by changing the BENDING PRISM (#24) as described below.

Step1: Loosen the CLAMP SCREW (#21) located on the backside of the Shear/Brake as shown in figure 4.

Figure 4 – Loosening the Clamp Screw

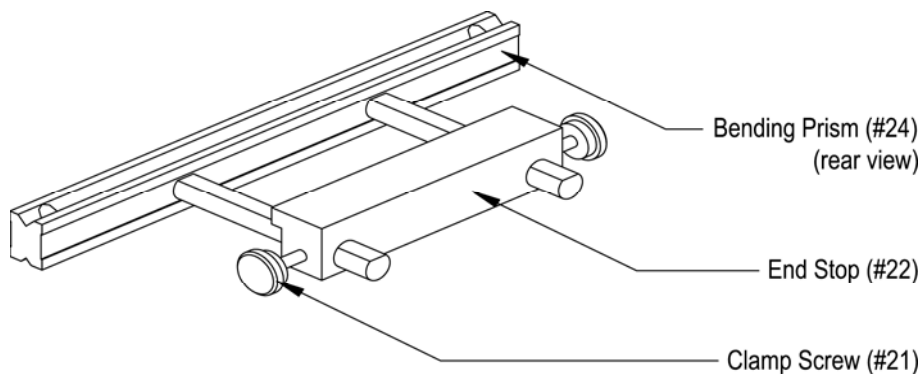

Step 2: Raise the HAND LEVER to raise the Bending Assembly.

Step 3: Lift the BENDING PRISM OUT OF THE GROBE IN THE base (#1). Pull the BENDING PRISM forward out of the END STOP(#22).

Step 4: Rotate the BENDING PRISM 180° to use the optional radius as shown in Figure 5. Fit the BENDING PRISM back into the groove.

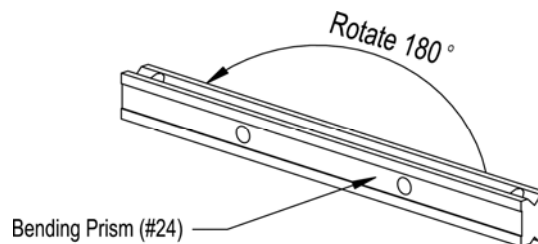

Figure 5 – Rotating the Bending Prism

Step 5: Slide the END STOP (#22) back onto the BENDING PRISM(#24). Tighten the CLAMP SCREW(#21).

Removal and Installation of Upper Cutter

Step1: Lower the HAND LEVER to lower the LOWER CUTTER (#31).

Step 2: Loosen the four MOUNTING SCREWS (#36) holding the UPPER CUTTER (#33) in place.

Step 3: Remove the UPPER CUTTER. If you have not used all four cutting edges, you can rotate the UPPER CUTTER to expose a sharp edge and reinstall without purchasing a replacement UPPER CUTTER.

Figure 6 – Removing the upper Cutter

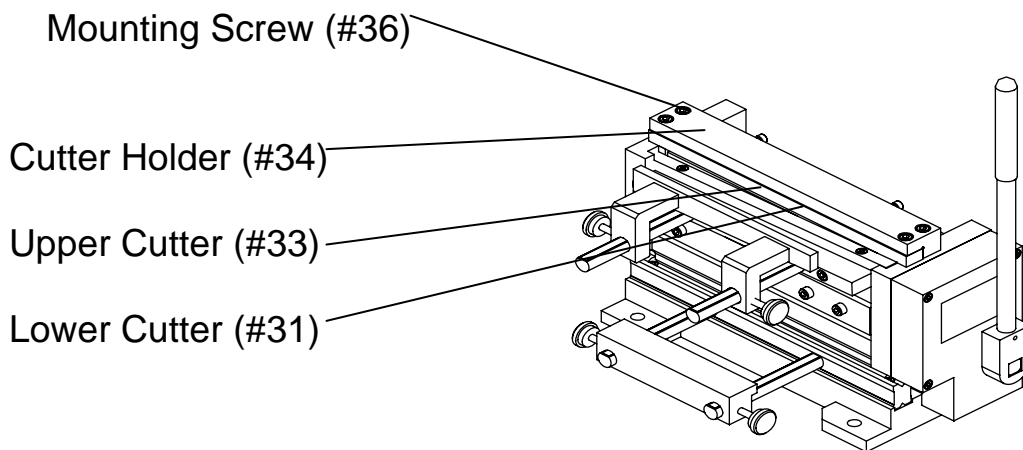

Step 4: Align the UPPER CUTTER (#33) so that it is flush with the LOWER CUTTER (#31) and secure with its MOUNTING SCREWS (#36).

Notice: The screws that hold the UPPER CUTTER (#33) must be tightened before tightening the CUTTER HOLDER Screws; otherwise, the cutter will jam.

Removal and Installation of Lower Cutter

Step 1: Raise the HAND LEVER to raise the LOWER CUTTER.

Step 2: Loosen and remove the two MOUNTING SCREWS (#32) for the Move Hammer (#30) as shown in Figure 7.

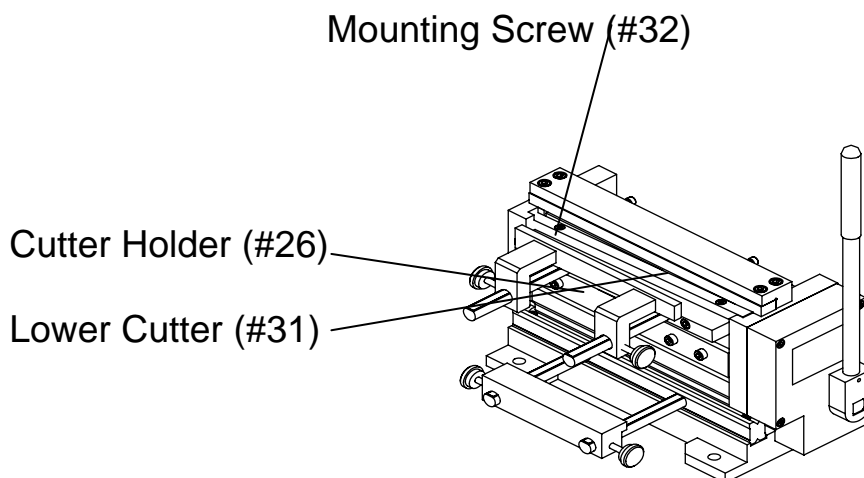

Figure 7 – Removing the Lower Cutter

Step 3: Press the flat of the LOWER CUTTER against the UPPER CUTTER with your thumb and lower the HAND LEVER. This will separate the LOWER CUTTER from the CUTTER HOLDER (#26).

Step 4: Remove and replace the LOWER CUTTER. There are four cutting edges on the LOWER CUTTER. If you have not used all four cutting edges, you can rotate the LOWER CUTTER to expose a sharp edge and reinstall without purchasing a replacement LOWER CUTTER.

Step 5: Press the LOWER CUTTER down against the CUTTER HOLDER.

Step 6: Raise the HAND LEVER. Insert and tighten the MOUNTING SCREWS.

OPERATION

Shearing

Step 1: Make sure the material you will be shearing is within the capacity of the tool. Do not use material that is thicker than the rated capacity for your Shear/Brake.

Step 2: Scribe the cutting mark on the material.

Step 3: Slide the material between the UPPER CUTTER (#33) and the LOWER CUTTER (#31) so that the UPPER CUTTER is positioned directly above the mark as shown in Figure 8.

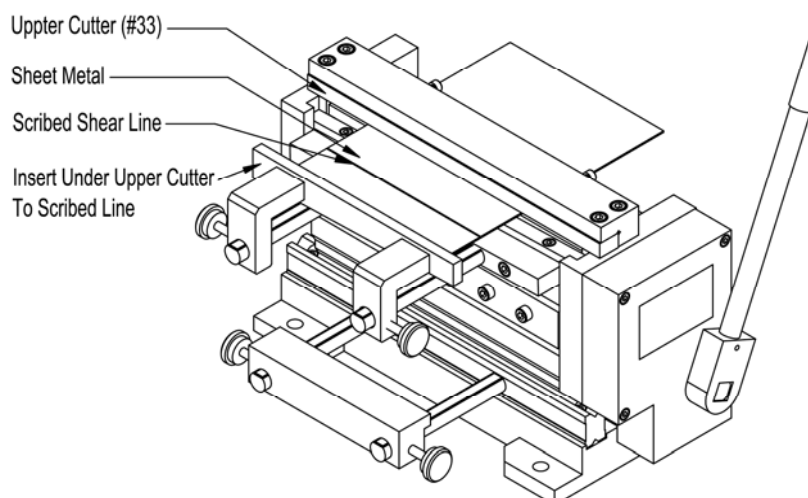

Figure 8 – Inserting scribed Sheet Metal

Step 4: While holding the material steady, lower the HAND LEVER (#6) until the material has been cut.

Angle Bending

Step 1: Make sure the material you will be bending is within the capacity of the tool. Do not use material that is thicker than the rated capacity for your Shear/Brake.

Step 2: Use the appropriate BENDING TOOLS and BENDING PRISM radius for your needs. Refer to the ASSEMBLY Step for adjustment.

Step 3: Mark the work place where you want to bend the material.

Step 4: Place material above the BENDING PRISM (#24).

Step 5: Align the bending mark with the front edge of the BENDING TOOL (S).

Step 6: Lower the HAND LEVER (#6) until the desired angle has been formed. Use a protractor or other measuring tool to ensure accuracy.

Pan forming

The Hand Brake Roll can be used to make various sizes of pans.

Step 1: Pre-measure and cut your material before bending. Notch the corners according to the desired lip height as shown in Figure 9.1.

Step 2: Insert material between the BENDING TOOL (S) and BENDING PRISM. Bend the material until a 90-degree angle has been formed as shown in Figure 9.

Step 3: Rotate the material 90-degree counterclockwise. Allow the completed side to extend just beyond the dies. Bend the second side.

Step 4: Repeat Step 3 for the third side.

Step 5: Rotate to the final side, and insert work piece between the dies. Your formed sides will be on the outside of the dies.

Step 6: Before bending tap one corner nearer to the middle of the machine as shown in Figure 9.3. This will allow the material to clear the UPPER DIE when raised.

Step 7: Bend the fourth side.

Step 8: Using a block or piece of wood, tap the corner of material back into place.

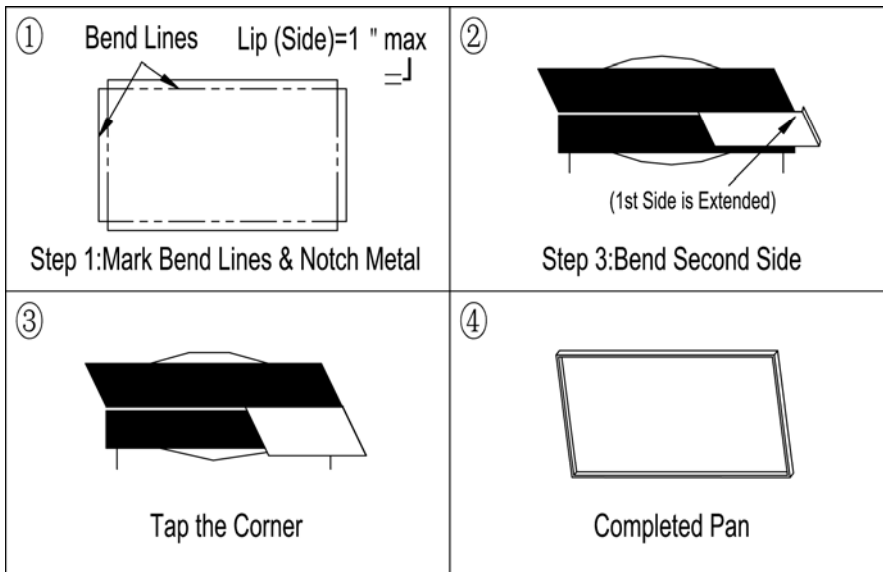

Figure 9 – Pan Forming

Radius Bending

Radius Bending is most commonly used to make cylinders and cones, as shown in Figure 10. Both shapes are formed by making a series of small, closely spaced bends in the work piece.

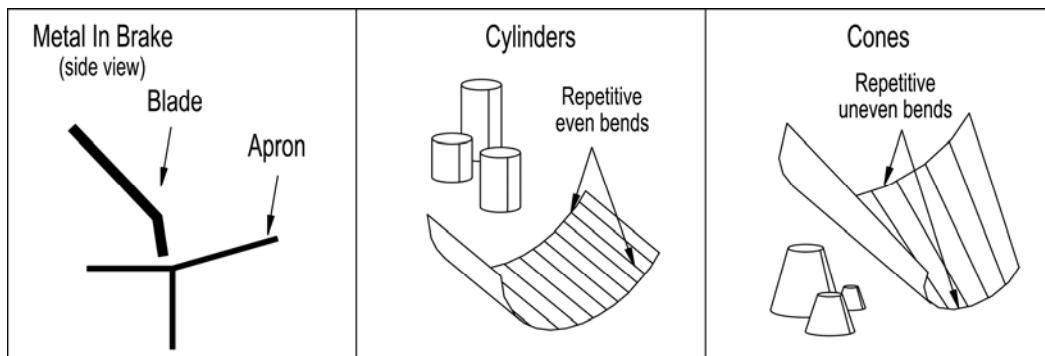

Figure 10 – Radius Bending

For cylinders, the bends are evenly spaced, i.e. every bend is identical.

For cones, simply move one side of your stock out further than the other every time you make a head.

PARTS LIST

No.	Description	Q'ty	No.	Description	Q'ty
1	Base	1	26	Press plate	1
2	Screw M5*20	4	27	Bending tool (I)	1
3	Driver shaft	1	28	Lower cutter end block	1
4	Bush	2	29	Sleeve	2
5	Fan gear	1	30	Move Hammer	1
6	Hand Lever	1	31	Lower cutter	1
7	Round pin 5*40	1	32	Screw M4*12	2
8	Driver shaft	2	33	Upper cutter	1
9	Gear	1	34	Upper cutter press plate	1
10	Set screw M4*6	1	35	Nut M4	2
11	Handle Pivot	1	36	Screw M5*25	4
12	Screw M4*35	4	37	Bending tool (II)	1
13	Gear Cover	1	38	T -block	1
14	Screw M6*30	2	39	Label	1
15	Taper pin 4*16	2	40	Small shaft (A)	2
16	Gear Support	1	41	End block	1
17	Gear	1	42	Move block (right)	1
18	Round pin 10*35	1	43	Move block (left)	1
19	Screw M4*25	4	44	Screw M4*10	2
20	Small shaft	2	45	Upper cutter label	2
21	Lock Screw	4			
22	Orientation block	1			
23	Staff guage	2			
24	Worktable	1			
25	Screw M5*12	4			

