

INSTRUCTION

- 1.Gauge Base
- 2.Measuring scribe
- 3.Battery Compartment
- 4.Main Carriage with LCD display
- 5.Column
- 6.Fine Adjustment Carriage
- 7.Fine Adjustment Nut
- 8.Fine Adjustment Carriage Lock
- 9.Main Carriage Lock
- 10.Function keys

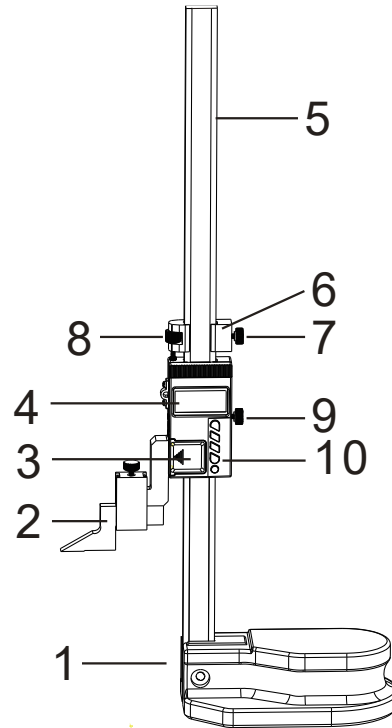

PRODUCT DETAIL

- Large easy to read LCD display
- Absolute Technology which memorize origin zero
- Resolution:0.0005"/0.01mm
- Accuracy:0.002"/0.05mm
- Indication variability:0.0005"/0.01mm
- SPC/USB data port
- Carbide tipped scriber
- ABS/INC measurement
- Battery:3V CR2032.

FUNCTION KEYS

- ON/OFF:turn unit on or off.
- mm/in key:switch between inch/metric.
- ABS/INC:Absolute/incremental measure.Press the key,screen will display 0.00 and INC (incremental) Press the key again,to disable the feature.
- Hold:hold display reading.
- Origin:Self memorizes and recognizes origin zero. Press key for 3 seconds to set origin zero.

CARE

- Keep the tool clean and dry.
- Avoid shocks or impacts.
- Avoid strong magnetic fields.
- Use with care.



WARNING

THE SAFETY INFORMATION GIVEN INSIDE MUST BE READ AND UNDERSTOOD BY ANY PERSON USING, INSTALLING, REPAIRING OR MAINTAINING THESE PRODUCTS