

ER collet system of VERTEX is made of special elastic steel material under excellent heat treatment and precise grinding process, so it has precise accuracy, powerful clamping ability, and is durable. This collet can clamp for a specific standard size and its next size, (Refer to the data sheet on page 2). It can be widely used for boring, milling, drilling and tapping as well as for grinding operation, and is available for all sizes.

## ER COLLET DIMENSIONS

TYPE	A	B
ER-8	8.5	13.5
ER-11	11.5	18
ER-16	17	27
ER-20	21	31
ER-25	26	35
ER-32	33	40
ER-40	41	46
ER-50	52	60

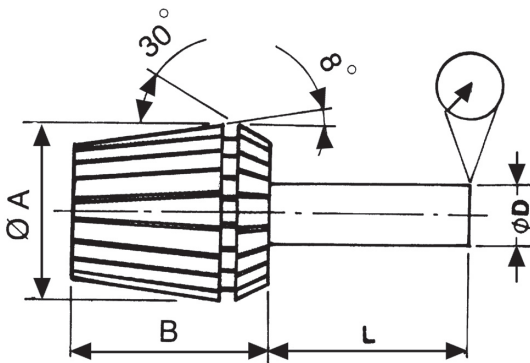

L mm	D mm	DIN6343 Standard precision	VERTEX Standard precision	A Grade Optional
6	1.0-1.4	0.02	0.015	0.01
10	1.5-2.9	0.02	0.015	0.01
16	3.0-5.9	0.02	0.015	0.01
25	6.0-9.9	0.02	0.015	0.01
40	10.0-17.9	0.03	0.02	0.01
50	18.0-26.9	0.03	0.02	0.01
60	27.0-34.9	0.03	0.02	0.01

THE HIGH PRECISION OF A GRADE IS AVAILABLE

double-taper chuck

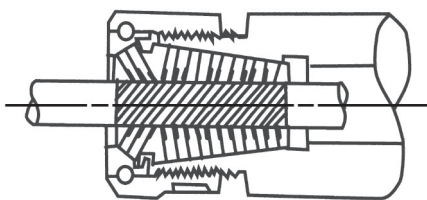

single-taper chuck

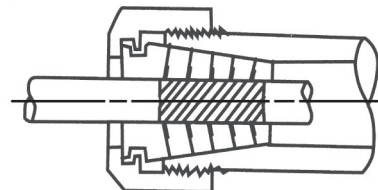

## POWERFUL CLAMPING STRENGTH

The handle of the drill with double-taper chuck is longer than that with single-taper (grinding spring) collet. The clamping strength will be more powerful, if a screw-driver fastened by steel ball is adopted.

## Mounting instructions for ER collets DIN 6499-A and DIN 6499-B

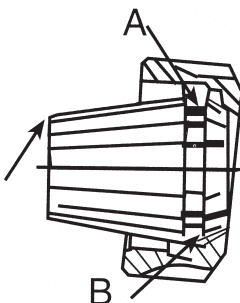

**A** - Place collet inside nut and rotate the nut to engage with the extractor spiral in collet groove.

**B** - Only then mount nut and collet together into the collet holder or machine spindle.

Note: Never use a 12-11mm collet to clamp a 12.2mm diameter, but rather use a 13-12mm collet.