

Installation Manual

1:Linear Scale Inspection.

Dear Distinguished Consumer,when you receive the linear scale,please check the linear scale detailedly and see if its corresponding installing accessories has been full provided,and don't forget to confirm whether the linear scale's measuring length meets the traveling length of the machines.The linear scale belongs to the accurate measuring instruments.Please avoid any crashes to it.If any damages,please contact the supplier.

2:Preparation for Installation.

Before proceeding the installation of the linear scale,please get ready of the necessary tools such as electric portable drill,screwdriver,dial indicator...etc.

3:Steps of Installation

3. 1: Before installation,the two screws on the red plastic piece(RPP) need to be screwed out.This red RPP gets two main functions,one is for reference of the distance between the readhead and scale body when doing the installing (pic.1),the other is for protection which can prevent the readhead moving during shipping.While the RPP should be removed after the installation is finished. (pic.2)



Figure 1

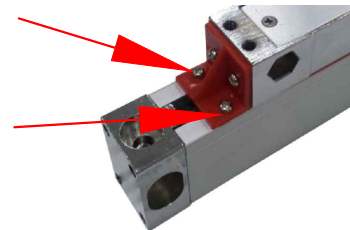

Figure 2

3. 2:Installation Method

To avoid the coolant liquid invade into the scale body,the scale should be mounted with the rubber strips(lips) facing down.Besides the dust proof need to be mounted for further protection if there is enough space.



Error



Okay



BEST

Installation Manual

3.3: Measuring Length of the Linear Scale

The measuring length of the linear scale should exceed the travelling length of the machine. When doing the installation, there should be extra length (around 10mm) that the readhead cannot reach at the two ends of the scale body.

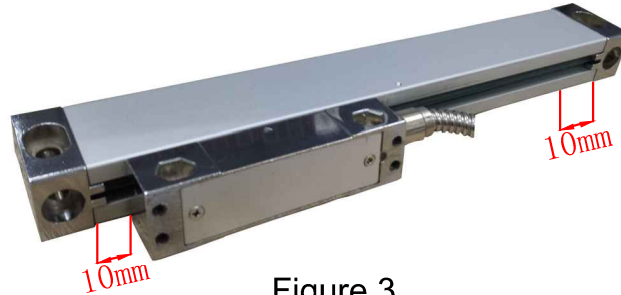

Figure 3

3.4: Installation Alignment

It is very important that the scale body be aligned parallel to the travel of the machine slide. If the platform on the machine is not good, we may use the pad strip as the base level, then mount the scale onto the pad strip (pic.4).



Figure 4

3.5: Adjustment of the Scale Body.

It is necessary to confirm whether the scale body is aligned parallel with the machine slide. For scale travel less than 950mm, the maximum parallel error between the scale body and machine slide must be less than 0.15mm. For scales travel longer than 950mm, the maximum parallel error should be less than 0.2mm. When using the dial indicator to align the scale, it is important to ensure that the dial indicator is perpendicular to the measured surface to avoid any error (pic.5).

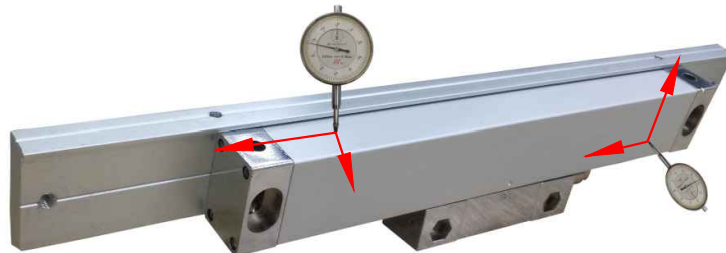

Figure 5

Illustration of the linear scale's installation

Case:

Our illustration covers mounting a two axis onto the milling machine. This milling machine gets a 800mm travel length for X axis, 400mm for Y axis. But for the installing, we choose 850mm measuring length scale for the X axis, 430mm measuring length scale for the Y axis.



Installation for X axis

Step 1: Confirm the installing location, install the scale's body onto the backside of the working table, place the readhead in the middle of the table. (pic.6). For this case, because the base level of the X axis is smooth, so there is no need to use the pad strip as the help of building a better base level.



Figure 6

Step 2: Find the installation hole

To find the coordinate of Y of the installation hole. Firstly, we need to measure the width of the end cap, and then draw a straight line from the right end to the left end basing the half value of the end cap's width. Ensure the bottom of the linear scale is parallel with the table's bottom. For this case, the value of the half width for this linear scale's end cap is 16mm, so the coordinate of Y is 16mm. (pic.7) Note: Different machines hold different installation position.

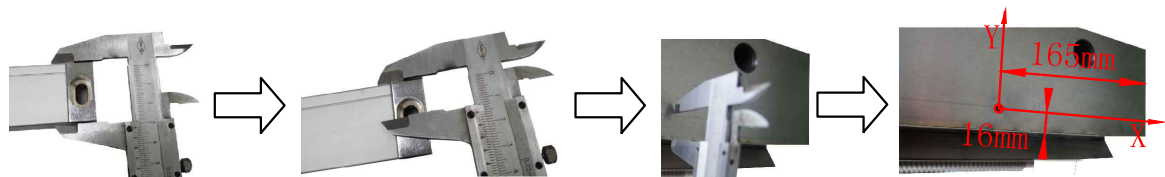

Figure 7

Installation Manual

To find the coordinate of X .Firstly we need to measure the length between the two installation holes.(pic 8)



Figure 8

Secondly,we need to measure the length of the table.In order to get the equal length from the end cap to the table end of the two sides after installing the linear scale on,we need to calculate the coordinate of X according to table length and the length between two installation holes.For this case,we get 1300mm for the table length,969mm for the length between the two installation holes,so we can get the length from the end cap to the table end is 165mm,Formula is $(1300-969)/2=165\text{mm}$. (pic9)Note:Different machines hold different installation position.

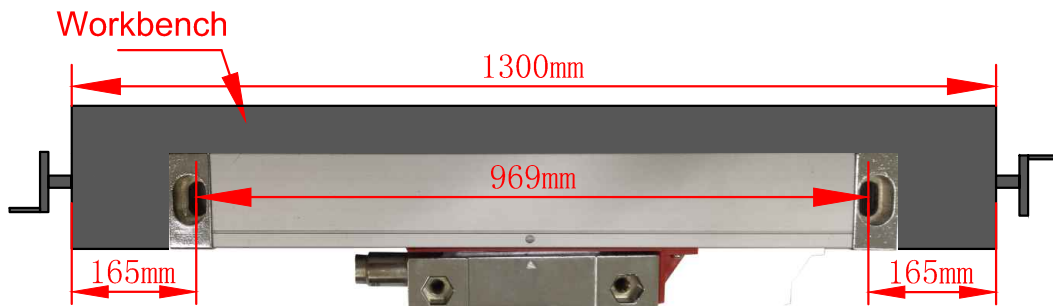
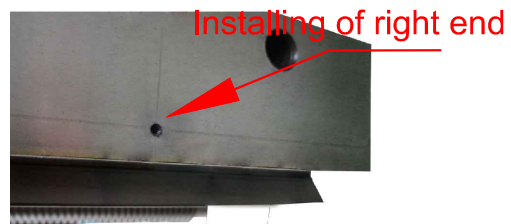

Figure 9

Step 3:Drilling and Tapping



Step 4:Installing the scale body



Installation Manual

Use the dial gauge to do the calibration after installing on the scale body. Wheel the table to the most left end in X axis direction, then place the dial gauge with the touch onto the scale body vertically. (pic10) After finishing this process, wheel the table to the most right end, watch the value changes on the dial gauge. If the value change is always below 0.15mm, we can tighten the screws.



Figure 10

If the value change is beyond 0.15mm, we need to use the shim as the help to build a better base level and make the value change be below 0.15mm. (pic 11)



Figure 11

After finishing the parallel calibration between the scale body and installation base level, we also need to do the parallel calibration between the scale body and table. Wheel the table to most left end first, then place the dial gauge with the touch onto the front of the scale body. (pic12). Then wheel the table to the most right end, during this process, we need to watch the value change on the dial gauge. If the value change is below 0.15mm, then there is no need to do any adjustment. But if the value change is beyond 0.15mm, we need to adjust the scale in up and down direction to ensure the value change is below 0.15mm.



Figure 12

Installation Manual

Step 5: To install the readhead, after installing the scale body well, then we need to install the readhead. Find the middle position of the table in axial direction to do the installation. (pic13)



Figure 13

Step 6: Drilling and Tapping. Move the readhead to the middle position we found. Then hold the readhead which let the height between the readhead and the body same as the height of the RPP to do the drilling. (pic14)



Figure 14

Step 7: Installation of the readhead. (pic15)



Figure 15

Installation Manual

During the readhead installation, we need to keep the readhead parallel with the scale body like plane1 and plane2.(pic16).If needed, then the shim will be the help to place them under the readhead to ensure the parallel.

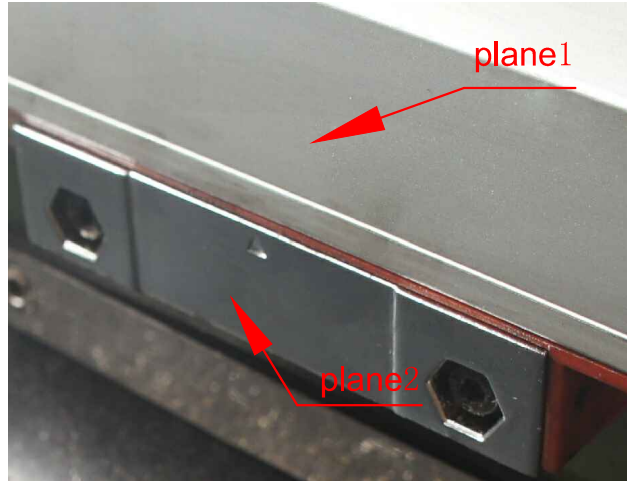

Figure 16

During the readhead installation, we also need ensure the distance between the readhead and body be same as the height of the RBP. If the distance is too large, it will affect the accuracy of the scale reading.



Figure 17

After the installation well, take out the RBP to finish the installation of X axi.(pic18)



Figure 18

Installation Manual

Installation for Y axis

Step 8: Confirmation of installing hole for Y axis. When proceeding this process, we need to wheel the table to the exact middle point, then draw a straight line as the below illustration. According to the measurement, the distance from the installing hole to the movable table plan is 100mm, the distance from the installing hole to the end is 20mm. (pic.19) Note: Different machines hold different installation position. Please proceed this process with the actual condition.

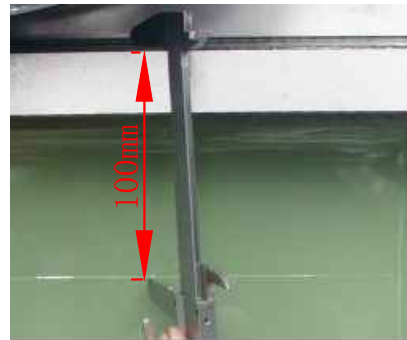
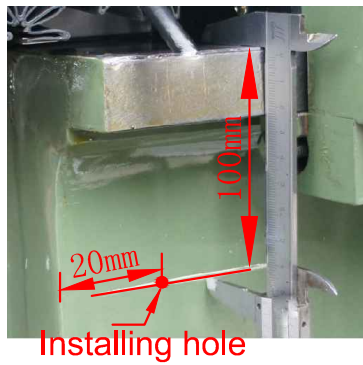

Figure 19

Step 9: Drilling and Tapping. (pic.20)



Figure 20

Step 10: Installing the scale body.

Since the pad strip will not be used for this case, so we may use the shims to build a higher base level for the scale body, thus there will be no direct contact between the brackets and the machine. (pic.21)



Figure 21

Installation Manual

Use the dial gauge to do the calibration when installing on the scale body. Wheel the table to the most left end in Y axis direction, then place the dial gauge with the touch onto the side face of scale body. After finishing this process, wheel the table to the most right end, watch the value changes on the dial gauge (pic22). If the value change is always below 0.15mm, we can tighten the screws.

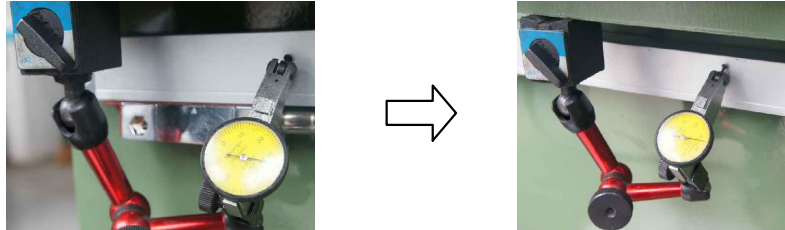

Figure 22

If the value change is beyond 0.15mm, we need to use the shim as the help to build a better base level and make the value change be below 0.15mm.

After finishing this parallel calibration process, we also need to do the parallel calibration between the bottom of the scale with the movable Y axis of the machine. Firstly we need to wheel the table to the most right end in Y axis direction. Then place the dial gauge vertically onto the scale body. The next step is to watch the value change on the dial gauge when wheeling the table to the most left end. If the value is below 0.15mm, that will be fine. (pic23)

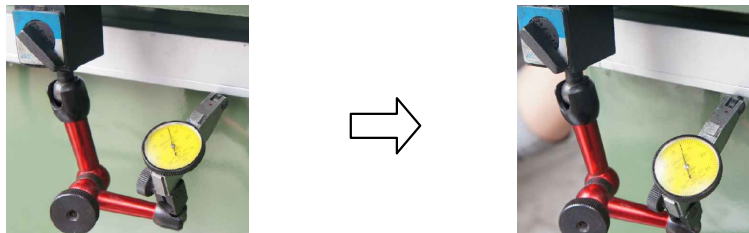

Figure 23

If the value change is beyond 0.15mm, we need to adjust the height of the scale body and make the value change be below 0.15mm.

Step11: Installing the Readhead. After finishing the calibration of the scale body, we come to the next step to install the readhead. When doing this installation, we need to use the brackets as a help. Thus when the table is moving, with the help of the bracket, it will drive the readhead move along the table. (pic24)



Figure 24

Installation Manual

When installing the brackets between the machine with the readhead, we need to wheel the table to the any most end, also place the readhead to the place which get 10mm distance to the end cape to ensure the travel of the Y axi is within the range of scale measuring length. After fixing the place of the table and readhead well, we need to adjust the height, then proceeding the installing.

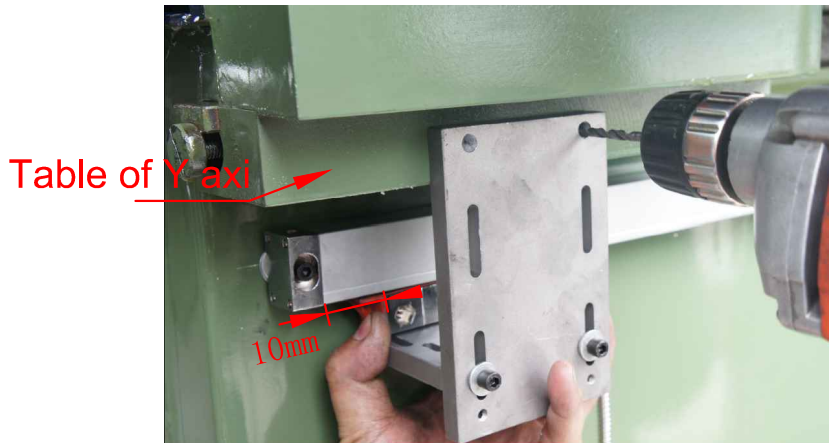

Figure 25

After adjusting well the height of the brackets, then drilling and tapping to install. (pic.26)

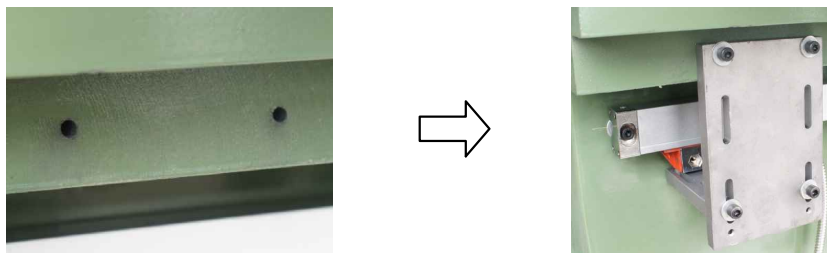

Figure 26

After installing well of the brackets, there is necessary to adjust the space between the readhead and the scale body. Keeping the space as the height of RBP will be fine. At this time, we need to adjust the height of installing plane of readhead. (pic.27)

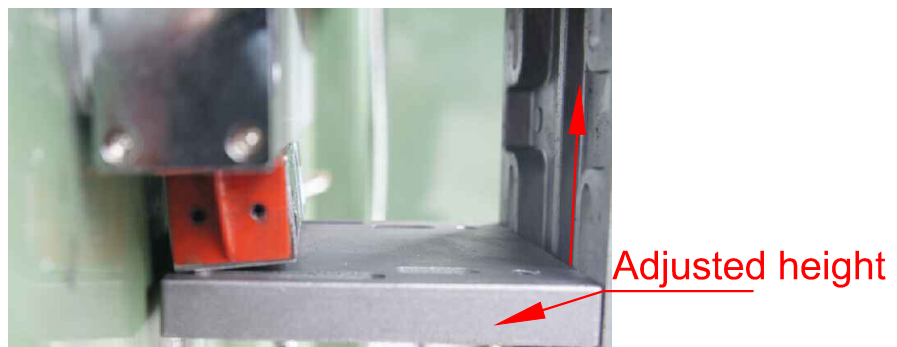

Figure 27

Installation Manual

When adjusting well the height of installing, the next step is to ensure the readhead be parallel with the scale body. Keeping it as plane 1 and plane 2 will be fine. (pic28).

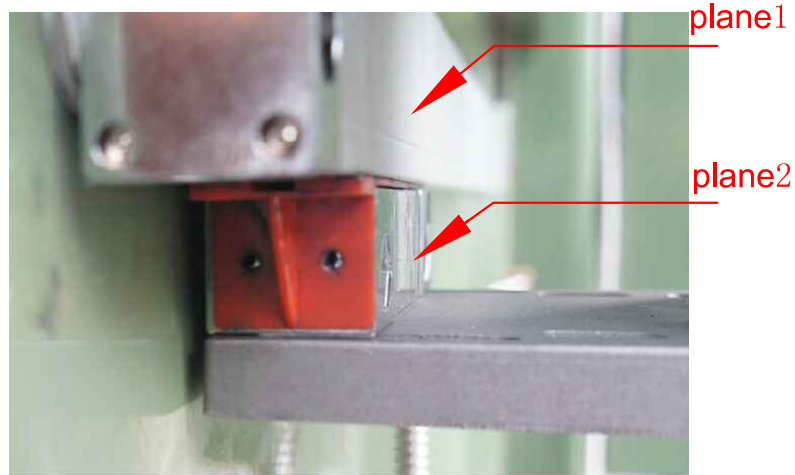

Figure 28

After the adjust well the readhead, then tighten the screw and take out the RBP.



Figure 29

When install well the readhead, it is necessary to watch the moving of Y axis to see if the readhead is moving smoothly. If any problem, please adjust according to the actual situation. (pic30)

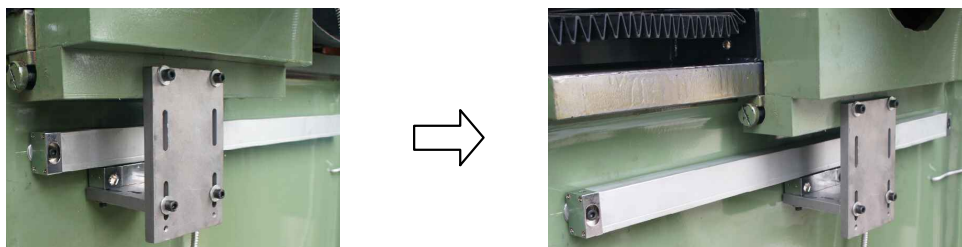

Figure 30

Installation Manual

LINEAR SCALE SIGNAL WIRING DIAGRAM

Linear Scale: Nine-pin TTL Signal Output Diagram

Pin	1	2	3	4	5	6	7	8	9
Signal	Empty	0V	Empty	Shield	empty	A	+5V	B	R
Color		Black		Shielding		Yellow	Red	Green	Brown

Linear Scale: Nine-pin RS-422 Signal Output Diagram

Pin	1	2	3	4	5	6	7	8	9
Signal	A-	0V	B-	Shield	R-	A	+5V	B	R
Color	Orange	Black	Blue	Shielding	White	Yellow	Red	Green	Brown

Linear Scale: Seven-pin TTL Signal Output Diagram

Pin	1	2	3	4	5	6	7
Signal	0V	Empty	A	B	+5V	R	Shield
Color	Black		Yellow	Green	Red	Brown	Shielding



Installation Manual

DC 10 Series Dimension Drawing

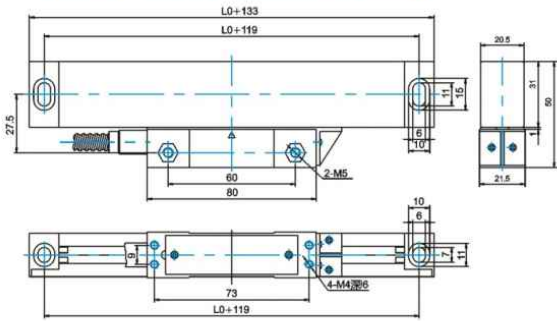

DC 20 Series Dimension Drawing

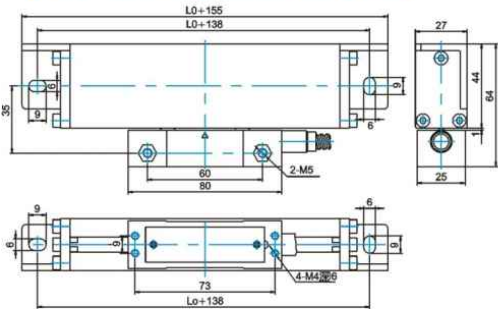

DC 30 Series Dimension Drawing

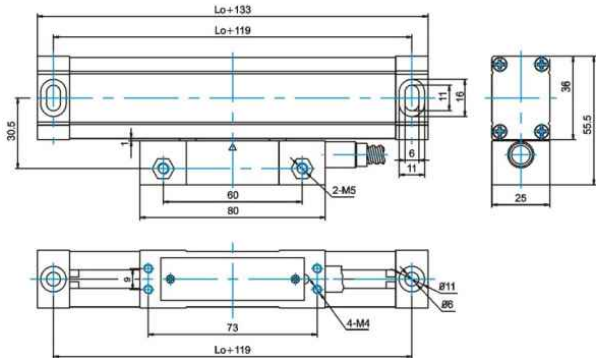

DC 10F Series Dimension Drawing

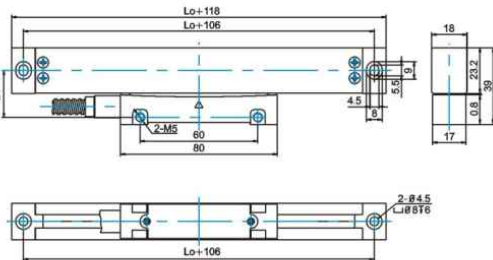

INSTALLATION ACCESSORY

